

## Disc Dosing Systems Series LA-M

Micro Processor controlled

Dosing of one or two colors or additives  
and mixing with virgin materials



### Special features:

- ✓ smart microprocessor control, software copyright by LANCO
- ✓ exact dosing of one or two small components to virgin materials
- ✓ digital volumetric dosing and perfect mixing of all components
- ✓ mixing hopper made from electro polished stainless steel
- ✓ prepared for combination with LANCO-hopper loading systems

Blender type	Article No.	volumes mixer and dosing stations in Liter	Throughput up to	Shot weight max. Gramm	electric load 3phase 400/50	Gross weight	Dimensions (wide x deep x h)
LA-M 1 / MK	1233.08	4 l 7 l	25 kg/h	500 g	0,3 kW	30 kg	680/320/600 mm
LA-M 1 / MN	1235.08	8 l 7 l	50 kg/h	1.000 g	0,37 kW	33 kg	720/400/640 mm
LA-M 1 / MH	1237.08	15 l 7 l	100 kg/h	2.000 g	0,45 kW	38 kg	720/400/750 mm
LA M 2 / MK	1234.08	4 l 2 x 7 l	25 kg/h	500 g	0,4 kW	42 kg	680/600/600 mm
LA-M 2 / MN	1236.08	8 l 2 x 7 l	50 kg/h	1.000 g	0,47 kW	47 kg	720/740/640 mm
LA-M 2 / MH	1238.08	15 l 2 x 7 l	100 kg/h	2.000 g	0,55 kW	52 kg	720/740/750 mm

Power supply: 3phase 400V, 50Hz, 3x16A pre fuse  
Voltage: 400 V, 50 Hz (Special voltage on request)

## LANCO - Colour Blenders Series LA-M

For best performance this blenders should be installed directly on the extruder inlet of processing machines replacing the original machine hopper. They work in a continuously self optimizing dosing mode in such a way that small portions of additives fall in the mixing chamber where an agitator makes a uniform mixture of all ingredients. A signal contact from the processing machine sends life signs to the controller.

For all possible additives like colour masterbatch, foaming agents, antistatic agents, stabilizers a. s. o. there are dosing stations available. Customized dosing stations for powders and liquids are possible.

On special request there can also be installed automatic loading systems on dosing stations for additives.

Interchangeable dosing stations that fit on the same dosing gear motors allow fast colour changes and set up.

A start up procedure that calculates based on the volume of the mixing hopper, the preset percentages of the additives and the bulk weight of the main component makes it easy to get stable colouring results after just a few shots of the processing machine. This saves time and reduces reject parts.

The inlet for the main material carries in most cases an automatic hopper loader. Automatic filling by gravity is a possible option.

Pre-dried resins can be processed with the standard blenders up to 80°C. Special high temp. versions up to resin temp. of 180°C are possible on special request.

Long life 3phase gear motors for dosing and mixing operations last for many years of operation.

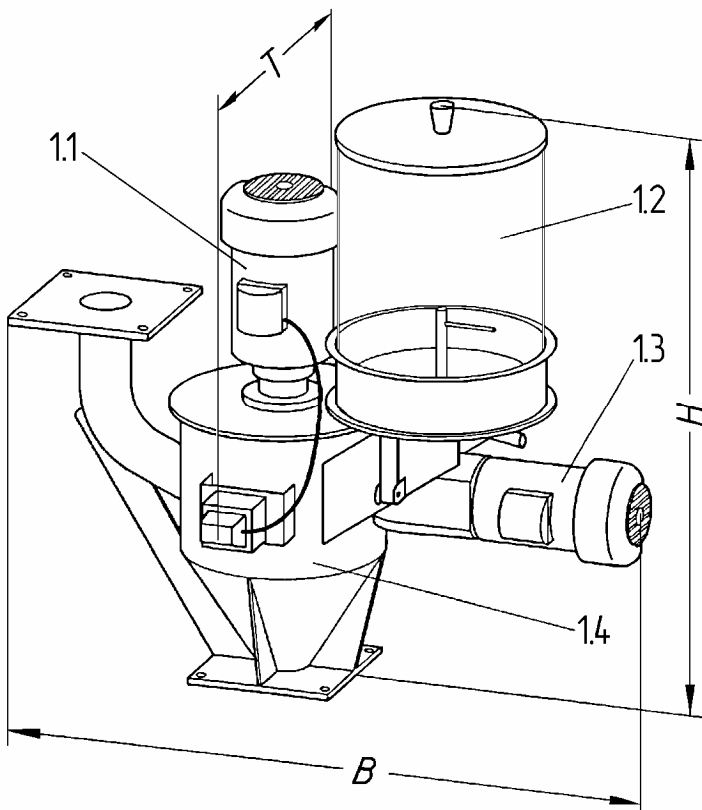

- 1.1 mixing gear motor
- 1.2 acrylic dosing hopper
- 1.3 dosing gear motor
- 1.4 mixing hopper

dimensions see chart

### Lanco GmbH

Moselstrasse 56-58  
D-63452 Hanau / Germany  
Tel: +49 (0) 6181 91600 - 0  
Fax: +49 (0) 6181 91600 - 40  
www.lanco.de